



# Product Change Notification

**Change Notification #:** PCN115116-00  
**Change Title:** Intel® Server Chassis R2312WTTYSR, PC115116-00, Product Design, Top screw removal, Change dimension on PCIe\* riser bracket holes, Hot Swap Back Plane Sheet Metal Locator Tab Modification

**Date of Publication:** November 22, 2016

## Key Characteristics of the Change:

Product Design

## Forecasted Key Milestones:

|   |                  |
|---|------------------|
| <b>Date Customer Must be Ready to Receive Post-Conversion Material:</b> | December 7, 2016 |
|---|------------------|

*Intel appreciates the customer's desire to receive the latest revision of products. However, Intel manages inventory on a first in first out (FIFO) basis at the MM# level. Subsequently, customer requests for a specific revision of material (below the MM#) will not be supported by Intel.*

## Description of Change to the Customer:

Intel is implementing the following changes on the Intel® Server Chassis R2312WTTYSR:

Next changes will be applied to the Intel® Server Systems R2312WTTYSR and Intel® Server Chassis R2312WTXXX:

1. remove three screws from the top cover
2. reduce length of the top cover

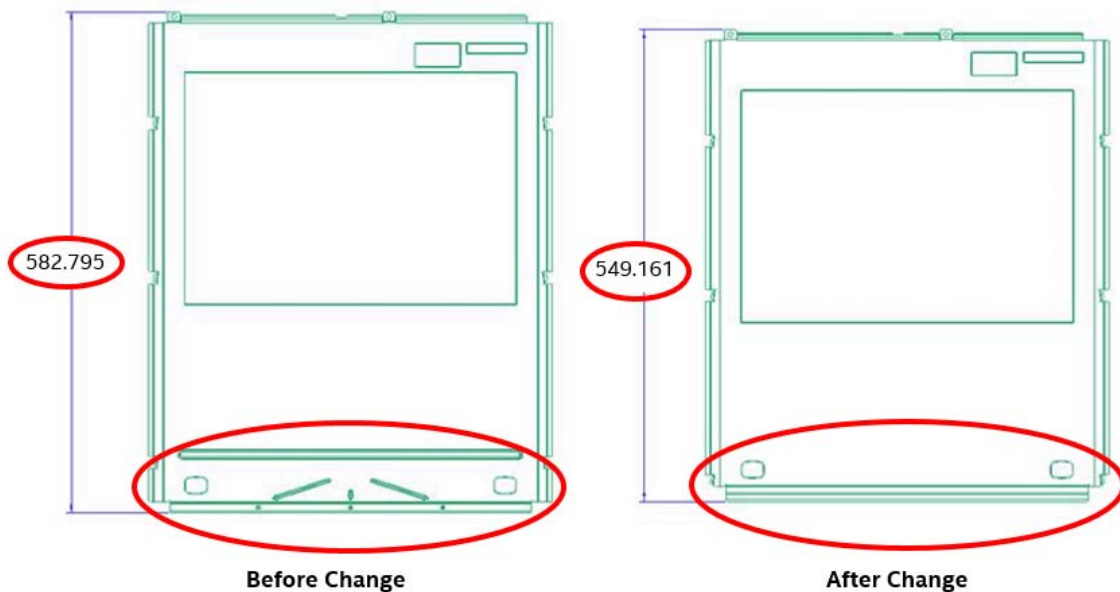

3. The width of the holes in the Peripheral Component Interconnect Express (PCIe) Riser bracket change from 2.4mm to 2.8mm. Please see image below for details:

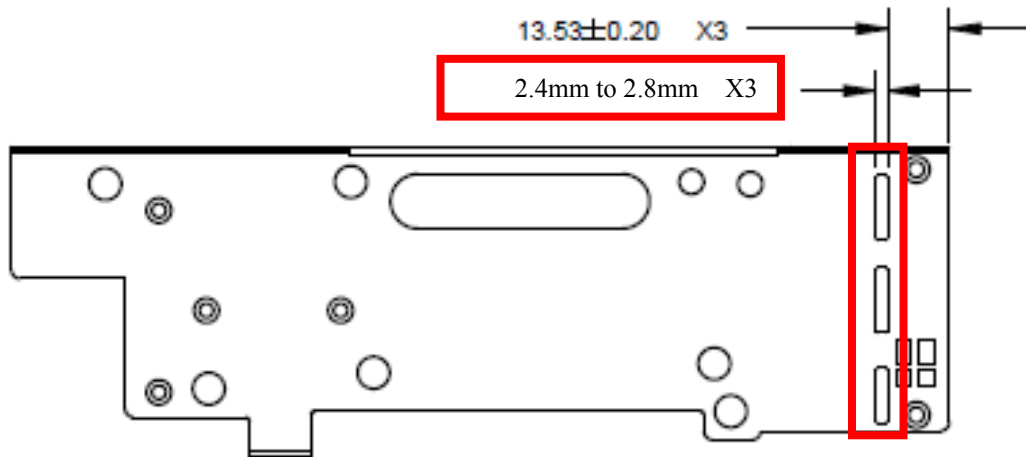

**Image 1.** PCIe\* bracket holes

This change will eliminate any difficulty with customers installing PCIe cards in riser 2 and riser 3 on opposing PCIe slots.

4. The sheet metal of the locator at the bottom tab of the hot swap back plane (HSBP) that is in the right side will be modified to ensure gap of 2.7mm. This modification is needed to provide reliable engagement between the drive and the backplane connectors. Please see additional information in the TA-1107 available at: <http://www.intel.com/content/www/us/en/support/server-products/000022064.html?wapkw=ta-1107>

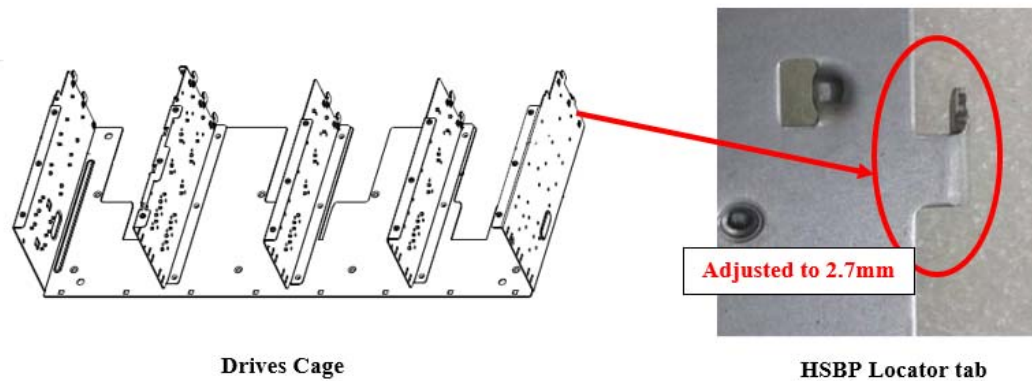

**Drives Cage**

**HSBP Locator tab**

### **Customer Impact of Change and Recommended Action:**

Intel does not expect any impact to customers from these changes, but encourages customers to understand the change and determine the impact on their applications. For that reason Intel recommends that the customer perform a standard level of evaluation.

Please contact your local Intel Field Sales Representative if you have any further questions about these changes.

### **Products Affected / Intel Ordering Codes:**

| <b>Product Code</b> | <b>MM#</b> | <b>Pre Change TA</b> | <b>Post Change TA</b> |
|---------------------|------------|----------------------|-----------------------|
| R2312WTTYSR         | 951229     | J11495-006           | J11495-007            |

### **PCN Revision History:**

|                          |                         |                          |
|--------------------------|-------------------------|--------------------------|
| <b>Date of Revision:</b> | <b>Revision Number:</b> | <b>Reason:</b>           |
| November 22, 2016        | 00                      | Originally Published PCN |



# Product Change Notification

## PCN 115116-00

**INFORMATION IN THIS DOCUMENT IS PROVIDED IN CONNECTION WITH INTEL PRODUCTS. NO LICENSE, EXPRESS OR IMPLIED, BY ESTOPPEL OR OTHERWISE, TO ANY INTELLECTUAL PROPERTY RIGHTS IS GRANTED BY THIS DOCUMENT. EXCEPT AS PROVIDED IN INTEL'S TERMS AND CONDITIONS OF SALE FOR SUCH PRODUCTS, INTEL ASSUMES NO LIABILITY WHATSOEVER AND INTEL DISCLAIMS ANY EXPRESS OR IMPLIED WARRANTY, RELATING TO SALE AND/OR USE OF INTEL PRODUCTS INCLUDING LIABILITY OR WARRANTIES RELATING TO FITNESS FOR A PARTICULAR PURPOSE, MERCHANTABILITY, OR INFRINGEMENT OF ANY PATENT, COPYRIGHT OR OTHER INTELLECTUAL PROPERTY RIGHT.**

A "Mission Critical Application" is any application in which failure of the Intel Product could result, directly or indirectly, in personal injury or death. SHOULD YOU PURCHASE OR USE INTEL'S PRODUCTS FOR ANY SUCH MISSION CRITICAL APPLICATION, YOU SHALL INDEMNIFY AND HOLD INTEL AND ITS SUBSIDIARIES, SUBCONTRACTORS AND AFFILIATES, AND THE DIRECTORS, OFFICERS, AND EMPLOYEES OF EACH, HARMLESS AGAINST ALL CLAIMS COSTS, DAMAGES, AND EXPENSES AND REASONABLE ATTORNEYS' FEES ARISING OUT OF, DIRECTLY OR INDIRECTLY, ANY CLAIM OF PRODUCT LIABILITY, PERSONAL INJURY, OR DEATH ARISING IN ANY WAY OUT OF SUCH MISSION CRITICAL APPLICATION, WHETHER OR NOT INTEL OR ITS SUBCONTRACTOR WAS NEGLIGENT IN THE DESIGN, MANUFACTURE, OR WARNING OF THE INTEL PRODUCT OR ANY OF ITS PARTS.

Intel may make changes to specifications and product descriptions at any time, without notice. Designers must not rely on the absence or characteristics of any features or instructions marked "reserved" or "undefined". Intel reserves these for future definition and shall have no responsibility whatsoever for conflicts or incompatibilities arising from future changes to them. The information here is subject to change without notice. Do not finalize a design with this information.

The products described in this document may contain design defects or errors known as errata which may cause the product to deviate from published specifications. Current characterized errata are available on request.

**Should you have any issues with the timeline or content of this change, please contact the Intel Representative(s) for your geographic location listed below. No response from customers will be deemed as acceptance of the change and the change will be implemented pursuant to the key milestones set forth in this attached PCN.**

**Americas Contact:** [asmo.pcn@intel.com](mailto:asmo.pcn@intel.com)

**Asia Pacific/PRC Contact:** [apacgccb@intel.com](mailto:apacgccb@intel.com)

**Europe Email:** [eccb@intel.com](mailto:eccb@intel.com)

**Japan Email:** [jccb.ijkk@intel.com](mailto:jccb.ijkk@intel.com)

Copyright © Intel Corporation 2016. Other names and brands may be claimed as the property of others.

BunnyPeople, Celeron, Celeron Inside, Centrino, Centrino Inside, Cilk, Core Inside, i960, Intel, the Intel logo, Intel AppUp, Intel Atom, Intel Atom Inside, Intel Core, Intel Inside, Intel Insider, the Intel Inside logo, Intel NetBurst, Intel NetMerge, Intel NetStructure, Intel SingleDriver, Intel SpeedStep, Intel Sponsors of Tomorrow, the Intel Sponsors of Tomorrow logo, Intel StrataFlash, Intel vPro, Intel XScale, InTru, the InTru logo, the InTru Inside logo, InTru soundmark, Itanium, Itanium Inside, MCS, MMX, Moblin, Pentium, Pentium Inside, Puma, skool, the skool logo, Sound Mark, The Creators Project, The Journey Inside, Thunderbolt, vPro Inside, VTune, Xeon, and Xeon Inside are trademarks of Intel Corporation in the U.S. and/or other countries.

Learn how to use Intel Trademarks and Brands correctly at <http://www.intel.com/intel/legal/tmusage2.htm>.